

PAD	CONNECTION
1	Enable / disable
2	Not connected
3	Ground
4	Output
5	Not connected
6	Supply

Scale 3:1

Specifications

Parameters	Product	Option Codes
	GXO-3302	
Frequency range:	0.50 ~ 45.0MHz	■
Frequency stability:	±10ppm	■
Operating temperature range:	-30 to +85°C	■
Storage temperature range:	-40 to +85°C	■
Supply voltage (V_{DD}):	+2.5V ~ +5.0V (see note)	■
Supply current (max):	10mA	■
Logic levels: '0' level = 10% V_{DD} max '1' level = 90% V_{DD} min		■
Start up time:	10ms max	■
Waveform symmetry:	45:55 @ 50% V_{DD}	■
Driving ability:	15pF HCMOS	■
Rise / fall time:	5ns max	■
Enable / disable function:	Tristate (control via pad 1)	■
Stand-by current:	10µA max	■
Period jitter RMS:	3ps typ	■
Phase noise (typ):	-140dBc/Hz @ 1kHz	■
Ageing:	±5ppm / year max	■

Features

- ▶ **High stability for WiMAX, LAN etc**
- ▶ **Miniature SM package**
- ▶ **Low voltage supply**
- ▶ **Enable / disable tristate function**
- ▶ **Competitive pricing**

Standard Frequencies

Frequencies in MHz		
31.25000	40.00000	44.00000

Other frequencies available. Please consult our sales office.

Ordering Information

Product name + frequency
eg: **GXO-3302 40.0MHz** ±10ppm, -30+85°C

♦ Will operate within specification on any supply voltage from +2.5V to +5.0V.

Enable / Disable Function

Input (pad 1)	Output (pad 3)
Open	Enabled
'1' level	Enabled
'0' level	High Impedance

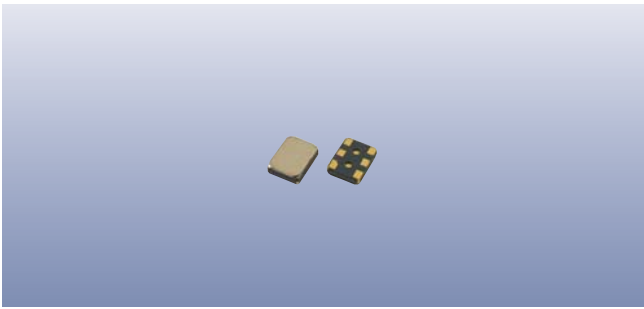

Construction

- Ceramic body with gold-plated pads*
- Metal lid, seam sealed*

Composition



This product is lead-free, and is fully compliant with the RoHS directive 2002/95/EC



Packaging & Handling

Production quantities supplied on T & R, 1k or 3k pcs per reel. Small quantities may be supplied on tape (no reel), or in bulk.



◆ Static sensitive product. Observe proper handling precautions

Marking

G02	DC
FREQUENCY	

Marking type: Laser
DC = Date code in YM, eg "CE" = May 2003

	A	B	C	D	E	F	G	H	J	K	L	M
Y	1	2	3	4	5	6	7	8	9	0		
M	Jan	Feb	Mar	Apr	May	Jun	Jul	Aug	Sep	Oct	Nov	Dec

Tape & Reel Specification

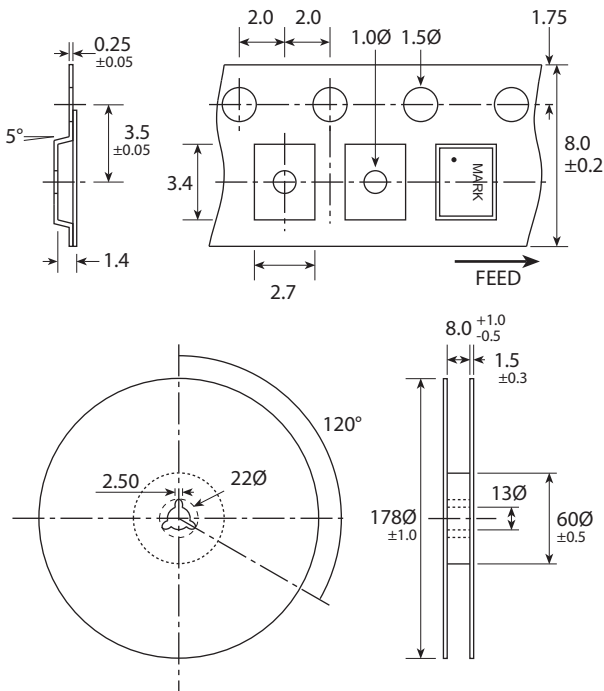

Not to scale. Dimensions in mm. Tolerances ±0.1mm unless otherwise stated

Soldering Profile

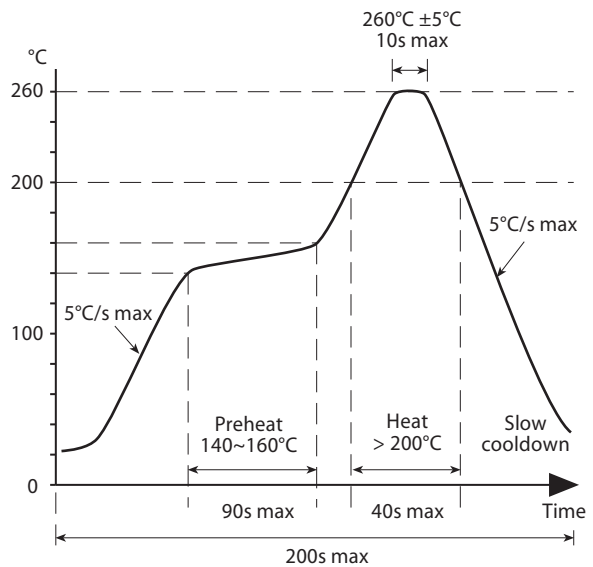

Solder resistance: 260°C x 10 secs x 2.